

INSTALLATION INSTRUCTIONS : COMPOSITE BEAM AND STEEL PERGOLA

1 CHOOSING THE COMPOSITE PROFILE Can be done in either of the 2 profiles below.

This is the preferred Profile.

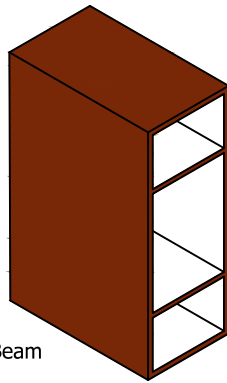

160 x 60mm composite Beam

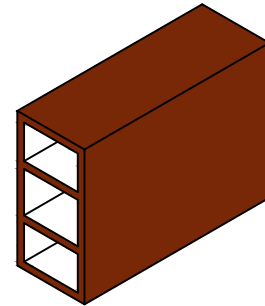

100 x 50mm Composite Beam

2 DETERMINE FIXING APPLICATION AND LAYOUT

- Subject to this specific installation requirements, there generally are 2 fixing scenarios.
1. Either the pergola Ring Beam will require vertical support footings to structurally secure it which would be secured into place with concrete.
 2. Or the pergola Ring Beam would sit between/against walls where the ring beam will be fixed directly to these facades.

This is Relevant to Option 1. The Diagram to the right shows the basic requirements for the hole used to support the vertical footings into the ground. The Depth of the hole must increase for additional support as the height of the pergola increases.

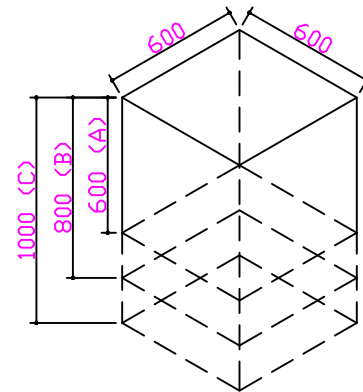

3 GENERAL INSTALLATION LAYOUT

- Each pergola is different and for the most case should not exceed the span 5.8m (Not always the case)
- The diagram below illustrates basically how one would start the process.
- Your vertical support footings which have been concreted in place or screwed through the steel to facades Option 2) are now ready to receive the steel ring beam.

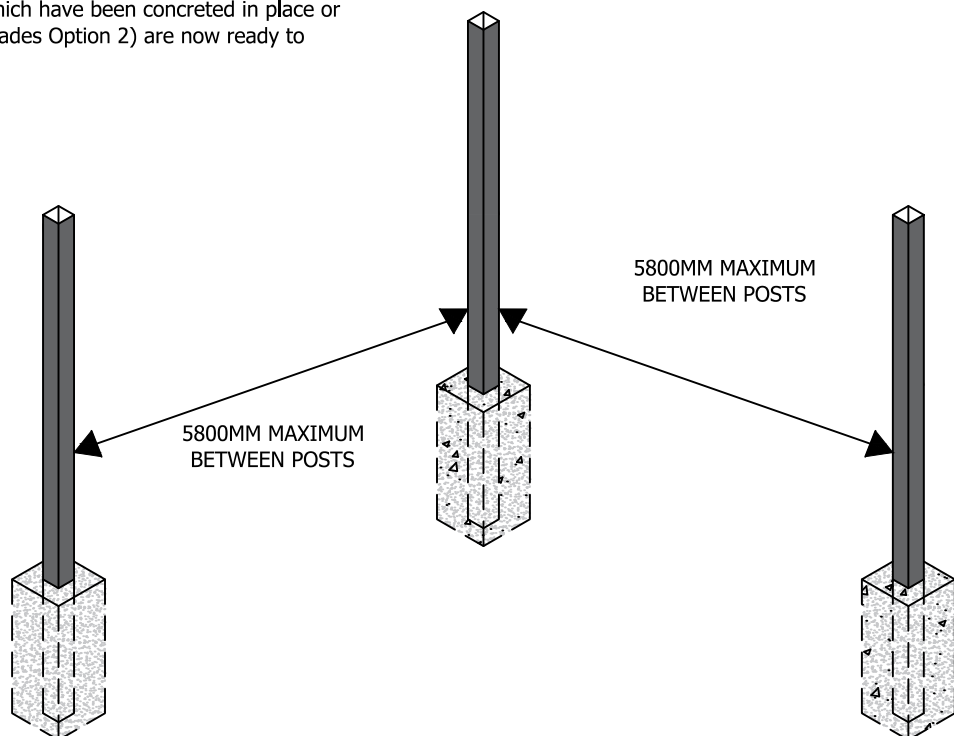

INSTALLATION INSTRUCTIONS : COMPOSITE BEAM AND STEEL PERGOLA

4 RAISING AND SECURING THE RING BEAM INTO POSITION

- The Ring Beam of the Pergola is constructed from either 100x100mm Square tube or 100x50mm Rectangle Tube (Wall thickness subject to span of material, This can change).
- The Ring Beam is secured to the vertical footings by welding them together.
- One now has a frame work to which the support bearer beams can be inserted and secured.

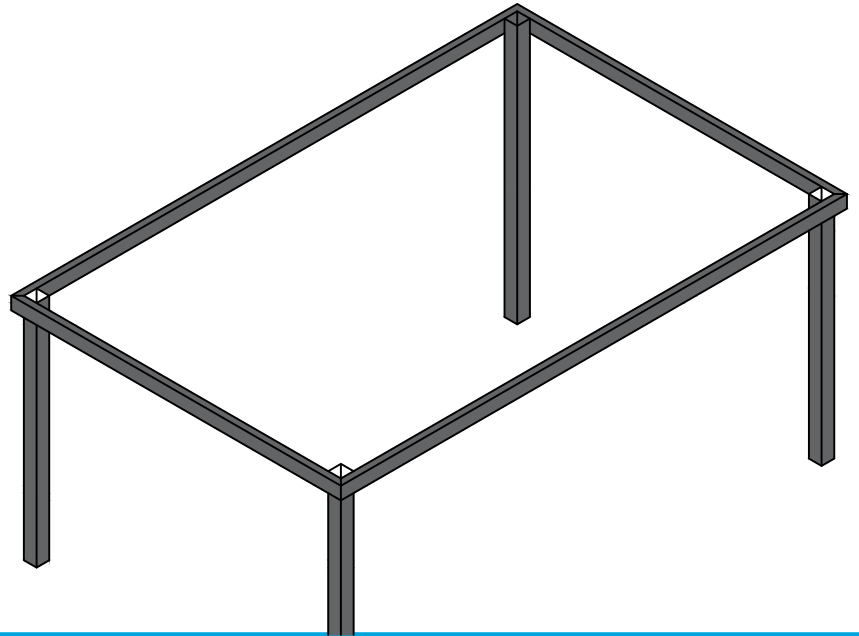

5 INSERTING BEARER SUPPORT BEAMS INTO THE CONSTRUCTED RING BEAM (NOTE Different bearer support spacing for the 2 profile options)

160 x 60mm profile - The Supporting bearers inserted are not to exceed the span of 1400mm

100 x 50mm profile -The Supporting bearers inserted are not to exceed the span of 900mm

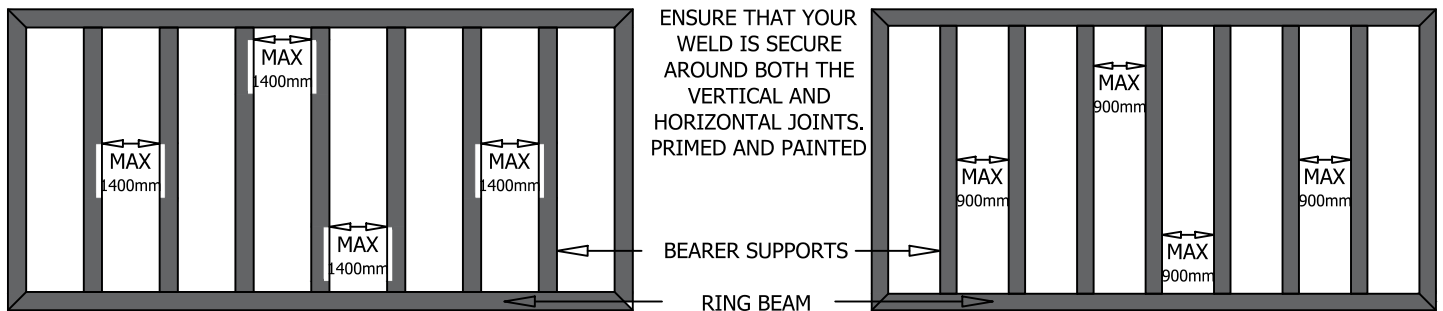

6 CONSTRUCTION OF U-SHAPED SUPPORT BRACKETS

STEP 1:

With a Galvanized Flat Bar, as per diagram below fabricate U-Shaped brackets to accommodate the composite wood profile. (160 x 60mm and/or 100 x 50mm)

STEP 2

The U-Shaped bracket that has been constructed Is designed to secure the composite profile. An 8mm or 10mm hole is drilled through the bracket depending on profile used.

8mm = 100 x 50mm profiles

10mm = 160 x 60mm Profiles.

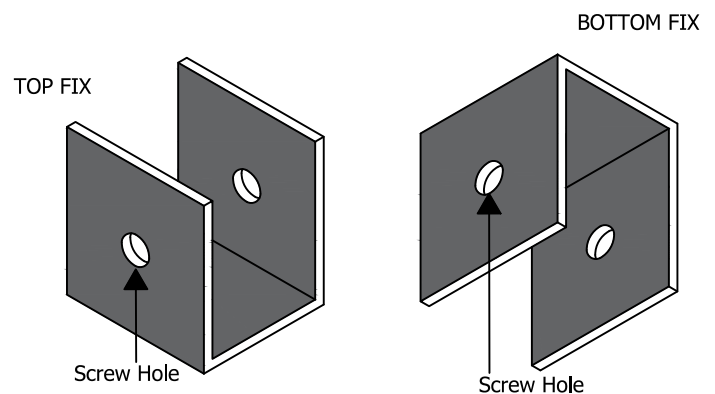
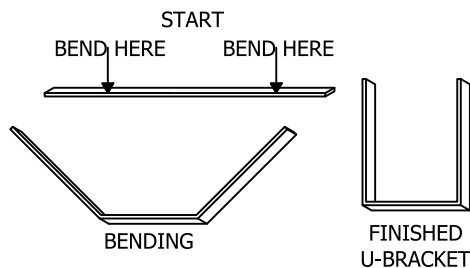

7 MOUNTING FIXING BRACKETS TO THE BEARER BEAMS

The U-Shaped Fixing brackets are welded to the supporting bearer beams

- The amount of brackets required will be determined by the spacing between the composite wood beams.

- There is no standard spacing, It is completely up to the end users discretion. The narrower the spacing between composite beams, the more beams one would require.

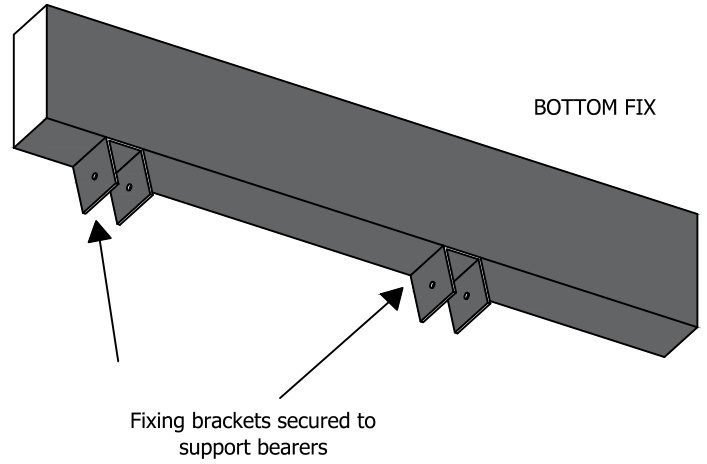
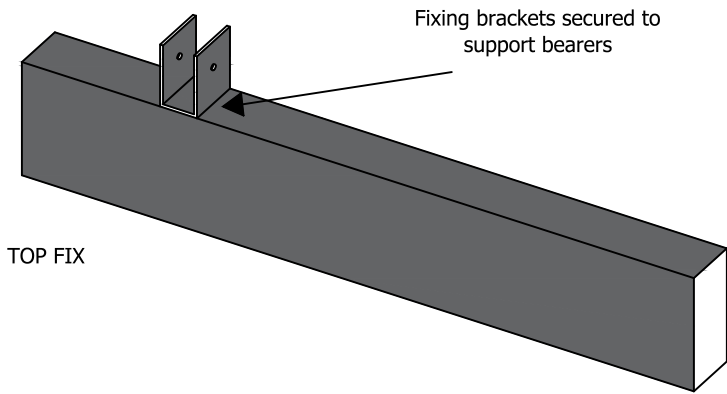

8 SECURING THE COMPOSITE WOOD BEAMS TO THE U-SHAPED BRACKETS

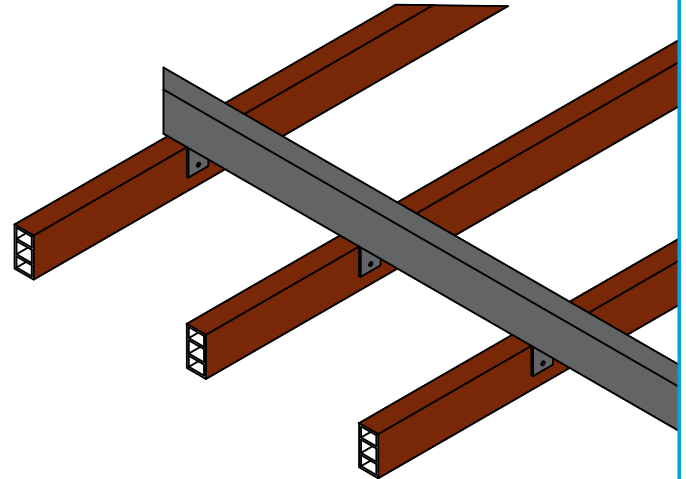
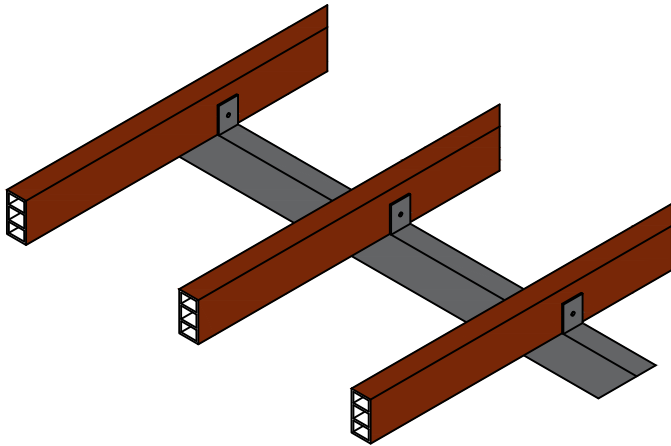

- Slot the composite wood beam into the constructed U-Shaped brackets.

- With your pre-drilled bracket, proceed to drill through the composite beam.

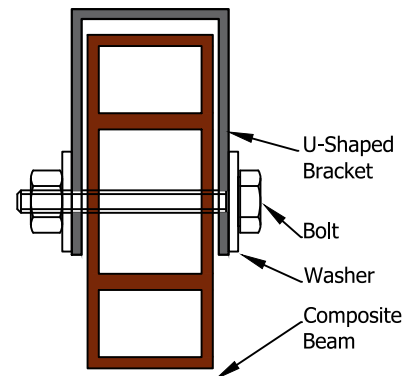
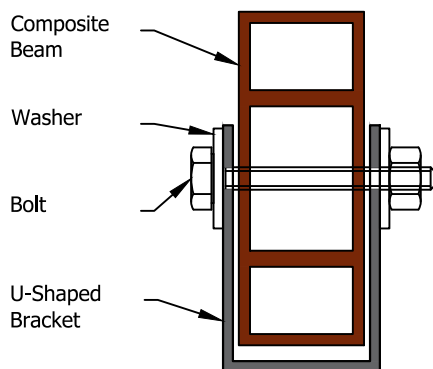

- Bolt and Nut**
With your pre-drilled bracket, proceed to drill through the composite beam. Depending on profile, either a 6mm diameter for the 100 x 50mm profile or a 8mm diameter for the 160x60mm profile. Screw, washer and nut are required to fix profiles to the bracket.

9 VISUAL REPRESENTATION OF COMPLETED PERGOLA

TOP FIX

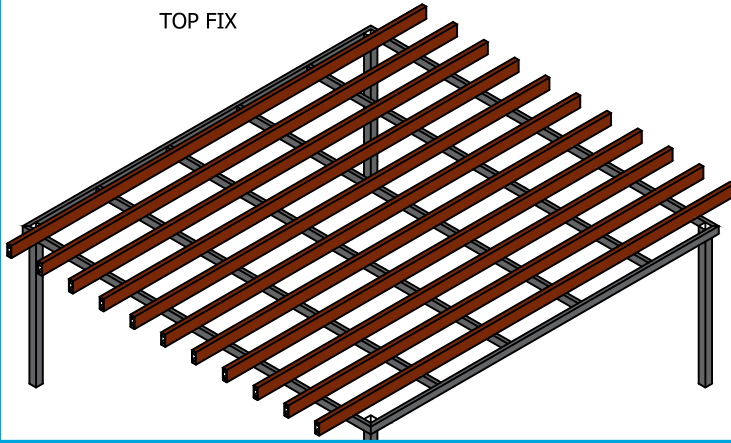

BOTTOM FIX

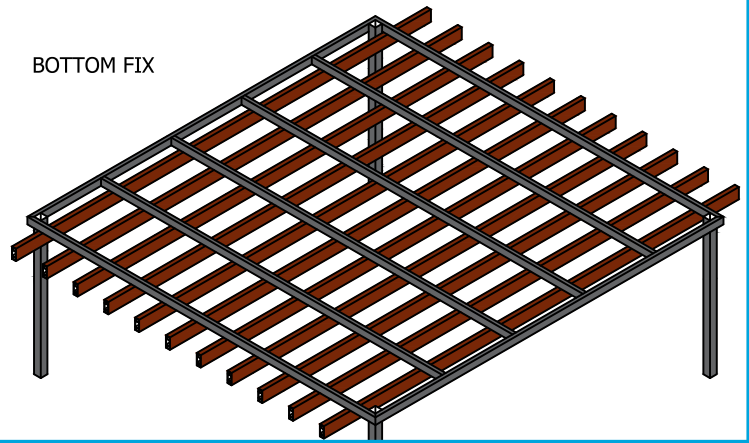

10 OPTION TO CLAD VISIBLE STEEL PROFILES

- With your pergola almost complete, one has the option either to paint the visible steel in a color of choice or to clad the visible steel using a composite fascia plank.

Using the fascia plank to clad visible steel adds an additional material cost. The finished pergola does always look smarter and rounded off with the steel clad.

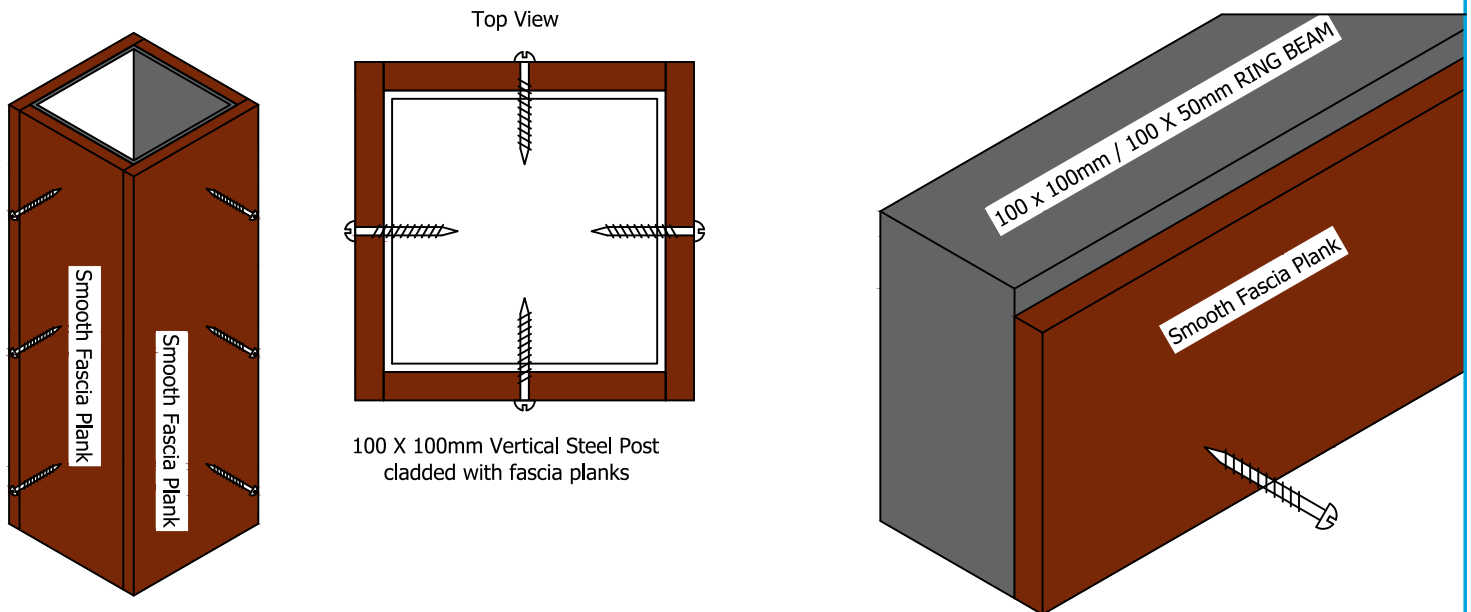

11 CLOSING OFF VISIBLE OPEN ENDS OF COMPOSITE PROFILES (We refer to the above as Capping)

- To Cap off the open ends of the composite profile, this is done using a Best Deck END cap.
- The end caps comes in the same size as the pergola beams making them fit snug.
- However we recommend applying contact adhesive glue to hold the end caps in place.
- Not too much as the glue is intended for the end cap only and not to be used on the actual Composite material.

